



IMPROVED CERTIFICATIONS SEARCH TOOL. REGISTER NOW!

[LEARN MORE](#)

System No. HW-D-0489 XHBN.HW-D-0489 Joint Systems

[Page Bottom](#)

Design/System/Construction/Assembly Usage Disclaimer

- Authorities Having Jurisdiction should be consulted in all cases as to the particular requirements covering the installation and use of UL Certified products, equipment, system, devices, and materials.
- Authorities Having Jurisdiction should be consulted before construction.
- Fire resistance assemblies and products are developed by the design submitter and have been investigated by UL for compliance with applicable requirements. The published information cannot always address every construction nuance encountered in the field.
- When field issues arise, it is recommended the first contact for assistance be the technical service staff provided by the product manufacturer noted for the design. Users of fire resistance assemblies are advised to consult the general Guide Information for each product category and each group of assemblies. The Guide Information includes specifics concerning alternate materials and alternate methods of construction.
- Only products which bear UL's Mark are considered Certified.

XHBN - Joint Systems

[See General Information for Joint Systems](#)

System No. HW-D-0489

February 11, 2008

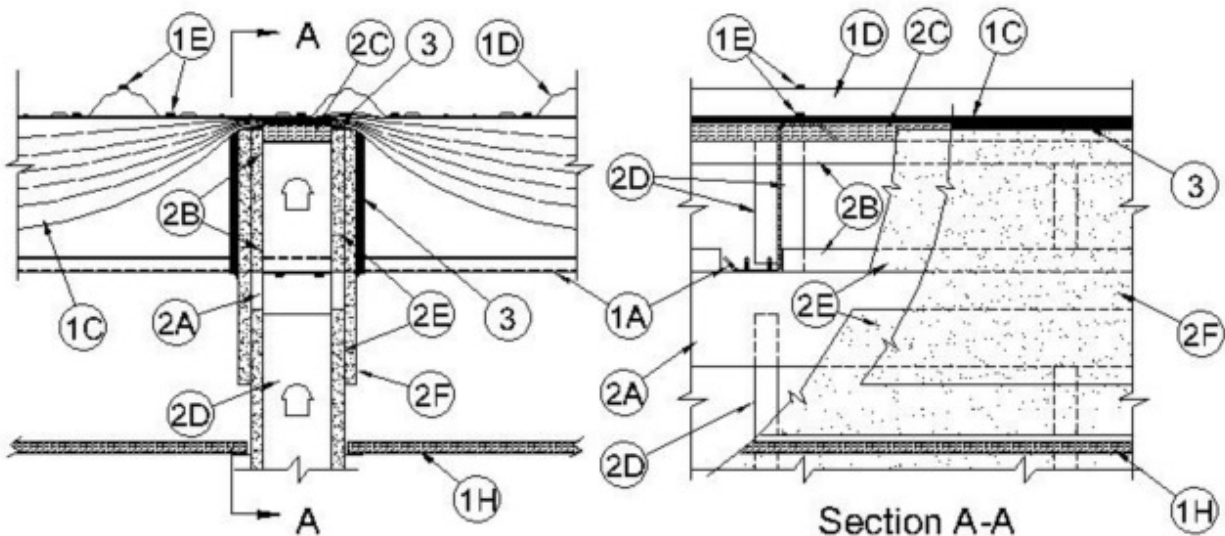
Assembly Rating — 1 Hr**Nominal Joint Width — 2 in.****Class II Movement Capabilities — 100% Compression and Extension**

1. Roof-Ceiling Assembly — The fire rated roof-ceiling assembly shall be constructed of the materials and in the manner described in the individual P200 or P500 Series **Roof-Ceiling Designs** in the UL Fire Resistance Directory and shall include the following construction features:

A. **Purlin** — Min 16 ga coated steel. Max spacing as specified in the individual **Roof-Ceiling Design**.

B. **Lateral Bracing** — (Not Shown) - As required.

C. **Batts and Blankets* - Insulation** — Any faced compressible glass-fiber blanket insulation having a min 6 in. (152 mm) thickness before compression and a min density of 0.6 pcf (9.6 kg/m³). Insulation draped over purlins prior to installation of panel clips (Item 1F) and/or metal roof deck panels (Item 1D). Side edges of the batts shall be butted or overlapped a max of 3 in. (76 mm).

See **Batts and Blankets** (BZJZ) category in the UL Fire Resistance Directory or **Batts and Blankets** (BKNV) category in the UL Building Materials Directory for names of manufacturers.

D. **Metal Roof Deck Panels*** — Min 26 ga coated steel. Panels continuous over two or more spans. Roof panel end laps, if required, centered over purlins with min 3 in. (76 mm) panel overlap as specified in the individual **Roof-Ceiling Design**. A line of tube sealant or tape sealant may be used at panel end and side laps.

See **Metal Roof Deck Panels** (TJPV) category in the UL Roofing Materials and Systems Directory for names of manufacturers.

E. **Fasteners** — Fasteners used for panel-to-purlin and panel-to-panel connections to be self-tapping, hex-head, plated steel or stainless steel screws with either an integral or a separate steel washer fitted with a compressible sealing washer. Fastener type, length, pilot hole diam and spacing to be as specified in the individual **Roof-Ceiling Design**.

F. **Roof Deck Fasteners* - Panel Clips** — (Not Shown) - Panel clips used for panel-to-purlin connections to be secured to purlin through insulation as specified in the individual **Roof-Ceiling Design**.

See **Roof Deck Fasteners** (TLSX) category in the UL Roofing Materials and Systems Directory for names of manufacturers.

G. **Thermal Spacer Blocks** — (Not Shown) - Expanded polystyrene strips cut to fit between panel clips (Item 1F) as specified in the individual **Roof-Ceiling Design**. Thermal spacer blocks, when used, are to be installed between insulation (Item 1C) and metal roof deck panels (Item 1D) over purlins.

H. **Ceiling Membrane — The Steel Framing Members*, Acoustical Material*, Gypsum Board*** and other ceiling membrane components shall be as specified in the individual **Roof-Ceiling Design**.

2. **Wall Assembly** — The 1 h fire-rated gypsum board/steel stud wall assembly shall be constructed of the materials and in the manner specified in the individual U400 or V400 Series **Wall and Partition Design** in the UL Fire Resistance Directory and shall include the following construction features:

A. **Ceiling Deflection Channel** — U-shaped channel formed from min 16 ga steel sized to accommodate steel studs (Item 2D) and provided with 5 in. (127 mm) flanges. Deflection channel installed perpendicular to purlins and secured to bottom flange of purlins with min No. 14 self-tapping, hex-head, plated steel or stainless steel screws.

B. **Steel Floor and Ceiling Runners** — Floor runner of the wall assembly and the floor and ceiling runners of the cripple wall above the wall assembly shall consist of min 1-1/4 in. (32 mm) deep min 25 ga galv steel channels sized to accommodate steel studs (Item 2D). Floor runner of cripple wall aligned with and screw-attached to top of ceiling deflection channel. Ceiling runner of cripple wall installed to compress insulation (Item 1C) to min thickness of 3/8 in. (10 mm) by wedging lengths of stud (Item 2D) between the runners. Steel studs of cripple wall attached to each side of purlin web and to floor and ceiling runners with steel screws.

C. **Batts and Blankets* - Packing Material** — Unfaced compressible mineral wool batt insulation having a nom 2 in. (51 mm) thickness before compression and a nom density of 4 pcf (64 kg/m³). Strips of nom 2 in. (51 mm) thick batt cut to width of cripple wall ceiling runner and compressed min 50 percent in thickness between cripple wall ceiling runner and insulation (Item 1C). Compression of mineral wool batt packing material to result in compression of insulation (Item 1C) to nominal 3/8 in. (10 mm) thickness.

See **Batts and Blankets** (BZJZ) category in the UL Fire Resistance Directory or **Batts and Blankets** (BKNV) category in the UL Building Materials Directory for names of manufacturers.

D. **Studs** — Steel studs to be min 3-1/2 in. (89 mm) wide. Studs cut max 2 in. (51 mm) less in length than assembly height beneath purlins with bottom nesting in and resting on the floor runner and with top nesting in ceiling deflection channel without attachment. Stud spacing not to exceed 24 in. (610 mm) O.C. Studs of cripple wall cut to length as required to compress packing material (Item 2C) and insulation (Item 1C) to min thicknesses of 1 in. (25 mm) and 3/8 in. (10 mm), respectively. Studs spaced max 24 in. (610 mm) OC.

E. **Gypsum Board*** — Min 5/8 in. (16 mm) thick gypsum board sheets installed on each side of wall. Wall to be constructed as specified in the individual U400 or V400 Series Design in the UL Fire Resistance Directory except that a max 2 in. wide gap shall be maintained between the gypsum board of the wall assembly below the purlin and the gypsum board of the cripple wall. Top edge of gypsum board of wall assembly to be max 2 in. (51 mm) below top of ceiling deflection channel. Bottom edge of gypsum board of cripple wall to be flush with top of ceiling deflection channel. Screws securing gypsum board to steel studs of wall assembly to be located 2-1/4 in. to 2-1/2 in. (57 to 64 mm) below flange of ceiling deflection channel. Screws securing gypsum board of cripple

wall to be driven into studs and runners of cripple wall. No screws are to be driven into flanges of ceiling deflection channel.

F. **Gypsum Board*** — Min 5/8 in. (16 mm) thick "rip strip" of gypsum board installed to cover first layer of gypsum board on cripple wall and to lap min 3 in. (76 mm) onto gypsum board of wall assembly on each side of wall. The "rip strip" of gypsum board is to be the same material used for the wall assembly and is to be secured to the studs and runners of the cripple wall. No screws are to be driven into flanges of ceiling deflection channel. Joints of "rip strip" to be offset from joints of gypsum board on wall assembly.

Max separation between top of wall assembly gypsum board and bottom of cripple wall gypsum board (at time of installation of joint system) is 2 in. (51 mm). The joint system is designed to accommodate a max 100 percent compression or extension from its installed width.

3. **Fill, Void or Cavity Material* — Caulk** — Min 5/8 in. (16 mm) thickness of fill material installed to fill any gap between top of cripple wall gypsum board and insulation (Item 1C) on each side of the wall. Additional caulk installed to fill annular space between purlin and gypsum board "rip strip" (Item 2F) on both sides of wall. Additional nom 1/2 in. (13 mm) diam bead of caulk to be applied around perimeter of purlin at its interface with the "rip strip" on each side of the wall.

3M COMPANY 3M FIRE PROTECTION PRODUCTS — CP 25WB+ caulk

*** Indicates such products shall bear the UL or cUL Certification Mark for jurisdictions employing the UL or cUL Certification (such as Canada), respectively.**

Last Updated on 2008-02-11

[Questions?](#)

[Print this page](#)

[Terms of Use](#)

[Page Top](#)

© 2018 UL LLC

The appearance of a company's name or product in this database does not in itself assure that products so identified have been manufactured under UL's Follow-Up Service. Only those products bearing the UL Mark should be considered to be Certified and covered under UL's Follow-Up Service. Always look for the Mark on the product.

UL permits the reproduction of the material contained in the Online Certification Directory subject to the following conditions: 1. The Guide Information, Assemblies, Constructions, Designs, Systems, and/or Certifications (files) must be presented in their entirety and in a non-misleading manner, without any manipulation of the data (or drawings). 2. The statement "Reprinted from the Online Certifications Directory with permission from UL" must appear adjacent to the extracted material. In addition, the reprinted material must include a copyright notice in the following format: "© 2018 UL LLC".